

Saffire™ EVO LZ-P

Exit Device Compatible Wi-Fi Lock



Applications

- Add smart locks for new construction projects or retrofits
- Get real-time notifications, including events and access anomalies
- Manage access rights to allow or revoke access for residents and visitors in real-time, from anywhere
- Easily send digital keys or PIN codes to residents and visitors from a mobile device
- Residents can use their mobile device, RFID credentials, or PIN to access their residence or common areas
- Provide convenient one-time or recurring access PINs to service and maintenance personnel
- Control when and where residents and visitors can go throughout the building
- Quickly delete lost access media to keep the building secure.

Overview

Saffire EVO LZ-P is an exit device compatible Wi-Fi lock that combines high-performance with aesthetics, seamlessly integrating with building technology providers and amenities for multihousing properties. The Saffire EVO LZ-P provides an easy-to-use, secure and flexible solution with the benefits of real-time connectivity. It includes the convenience of using either mobile devices, RFID credentials or secure PINs for access to resident units, common areas and perimeter doors.

Security with IoT connectivity

The Saffire EVO LZ-P is equipped with Wi-Fi onboard, ensuring connectivity to the dormakaba Lyazon cloud and seamless

integration to our Lyazon partner platforms for real-time events and user notifications. Online connectivity of the Saffire EVO LZ-P also provides continuous updates for built-in device security.

Designed for our aggregator partners

The Saffire EVO product portfolio is specifically designed to be integrated with our dormakaba Lyazon partner platforms to ensure a premium user experience for multifamily residents. The dormakaba Saffire EVO cloud-connected smart locks allow easy access management of residences, amenities, common areas and perimeters, all through a single integrated platform.

Security features

- Online connectivity ensures continuous firmware updates for increased device security
- UL 10C 3-hour fire rating
- Non-volatile memory maintains lock programming and audit records
- Staff monitoring with RFID keycard audits
- Tamper-proof design
- No need to visit the lock to update access

Factsheet

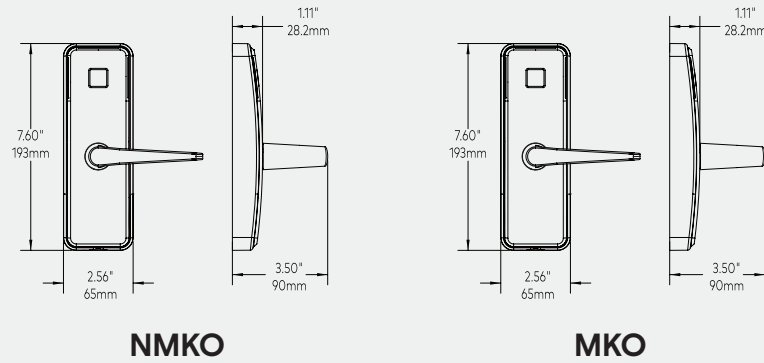

Mechanical Features

Description	Online connectivity ensures continuous updates for increased device security. Supports dormakaba RFID, Bluetooth, and keypad credentials
Handing	Left or right factory-handed, (field-reversible)
Levers	Essen, Von and Long return
Finishes**	626 satin chrome, 606 satin brass, 619 satin nickel, 625 bright chrome , 613 oil-rubbed bronze, and 622 black.
Door Thickness	Option 1: 1-3/4" - 2" (45mm to 51mm) Option 2: 2" - 2-1/4" (51mm to 57mm)
Locking Options	Designed for compatibility with a wide selection of exit devices (see price book for complete listing)
Batteries	3AA. Low-battery indicator to help with preventative maintenance. It is visible on the device and has an event notification in the system. Passive warning and notification.
Concealed Key Override	Optional MKO: Lori KIK core (keyed-alike, master key)
Electronic Battery Backup	Electronic lock power supply (ELPS) battery back-up. ELPS part number 118-515990
Wi-Fi Online Control	Wi-Fi 802.11 b/g/n WPA2, WPA AES 128 and TLS 1.2>/-70dB signal strength at the lock

** dormakaba utilizes PDV (physical vapor deposition) finishes in some instances

Mobile Access

BLE Enabled	Bluetooth Low Energy 2.4 GHz version 4.2, iOS or Android mobile device support, AES 128 and DTLS security, supported through partner mobile app
--------------------	---

Lock Operation

No Touring	New credentials applied to lock through Wi-Fi
Electronic Access	User defined: customizable access for residents, visitors and property managers available through partner application
Date/time Stamp	Real time: date and hours/minutes; automatically adjusts for daylight saving time
Audit Trail	Audit trail managed through Wi-Fi. 5,000 events
Passage Mode	Set by authorized key
Lockout Mode	Set by authorized key
Toggle Mode	Use of credential is needed to lock the door after exiting unit. This stops accidental resident lockouts and delivers full audit trail to ownership/management
Credential Formats	dormakaba ComID high-security credentials 13.56MHz MIFARE DESFire EV2/EV3 ISO card or fob/mobile access credentials (BLE) / 6-digit PIN codes
Feedback LED	Light indicators
Diagnostics	Lock diagnostics through partner application
Privacy Override	Default emergency key only (user selectable)

Certifications & Testing

Certification	ANSI/BHMA A156.25
Fire Rating	Meets UL 10C and ULC S-104, on fire door rated up to and including 3 hours
Electronics	Compliant with RED Directive 2014/53/EU for electromagnetic compatibility and FCC part 15 and RSS-247 Industry Canada requirements
Environmental Operating Conditions	-31°F to 158°F (-35°C to 70°C), 0% to 90% non-condensing humidity at 86°F (30°C) meets IP54

Warranty

Standard Warranty	Two years
--------------------------	-----------

Exit Device Operators

dormakaba offers a series of exit device hardware that is compatible with mechanical and electrical applications. This hardware is manufactured for the most demanding access/egress applications.



Rim Exit Device

The Dorma 9300 series is a single-point rim latch with a modern touch bar design.

Vertical Rod Exit Device

The Dorma 9400 series is a surface-mounted vertical rod exit device with a modern touch bar design.

Hand	Non-handed
Stock	36" door width (standard); 48" door width available at an upcharge
Door types	Wood, hollow metal, fiberglass, or aluminum
Door requirements	Fits standard 1 3/4" - 2 1/4" doors
Mounting height	40" above finished floor
Stile width	4 5/8" with standard 99 strike 4 1/8" with optional 98 strike
Latch bolts	Stainless steel dead-locking; Pullman-type top latch
Finishes*	605 bright brass; 606 satin brass; 611 bright bronze; 612 satin bronze; 613 oxidized satin; 619 satin nickel; 693 black; 625 bright chrome; 626 satin chrome; 629 bright stainless; 630 satin stainless

*Check availability of finishes for devices and corresponding locks before ordering. Other powder-coated finish options available.

Other panic bar options available, for details, contact your dormakaba representative.

Any questions? We would be happy to advise you.

Contact us at: 1 800 849 8324